



INST.410

Concealed Overhead Holder

Installation Instructions

OVERHEAD HOLDERS OR STOPS MUST BE INSTALLED BEFORE CLOSERS

1. A. DETERMINE THE MOUNTING BEING USED FROM ILLUSTRATION BELOW.
- B. SELECT MOUNTING GROUP NUMBER FROM THE CHART BELOW. MOST CONTINUOUS HINGES ARE GROUPED WITH 4 1/2" WIDE BUTT OR 4 1/2" SWING CLEAR HINGE.
- C. USING THE MOUNTING GROUP NUMBER AND THE OVERHEAD HOLDER OR STOP SIZE AND THE DEGREE OF OPENING DESIRED, FIND "A", "B", "C", "D", AND "E" DIMENSIONS FROM CHARTS ON PAGE 3 THRU 6. FOR DEAD STOP ADD 9/16" (14) TO THE "A" DIMENSION FROM THE CHART. SEE NOTE D FOR INFORMATION ABOUT DEAD STOP.

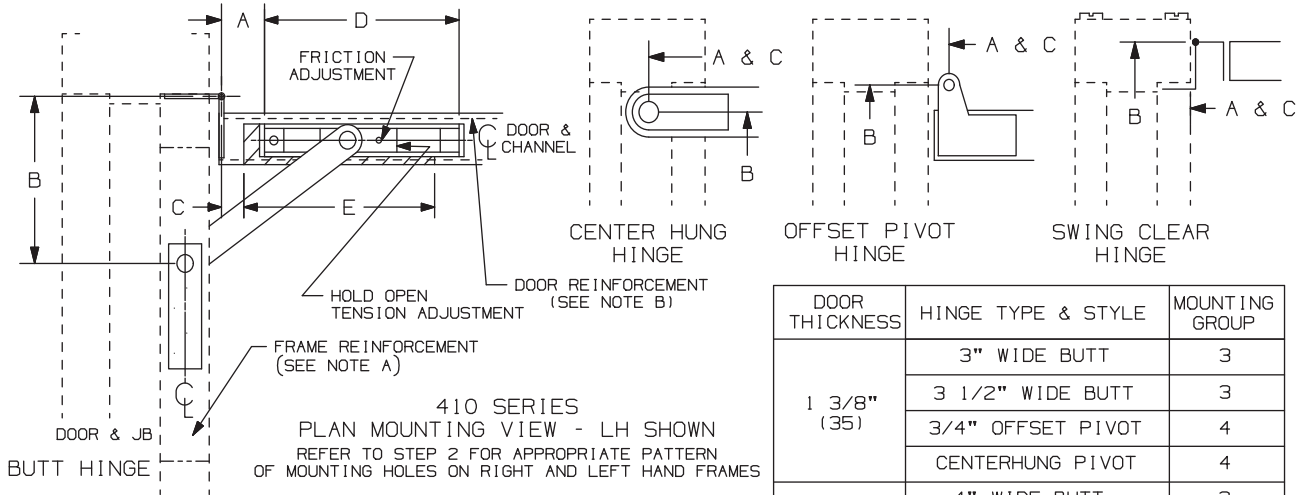

NOTES:

- A. HOLLOW METAL FRAMES SHOULD BE PROPERLY REINFORCED WITH A 3/16" (5) MINIMUM THICKNESS BY 12" (305) MINIMUM LENGTH PLATE.
- B. HOLLOW METAL DOORS SHOULD BE PROPERLY REINFORCED WITH A 3/16" (5) MINIMUM THICKNESS PLATE.
- C. STOP ONLY UNITS ARE PERMITTED ON MANY FIRE DOOR APPLICATIONS. HOWEVER, MECHANICAL HOLD-OPEN DEVICES THAT REQUIRE MANUAL RELEASE ARE NOT PERMITTED FOR USE ON ANY FIRE DOOR AS OUTLINED ON NFPA80 (R) OR NFPA101 (R). CONTACT GLYNN-JOHNSON OR YOUR LOCAL REPRESENTATIVE FOR ASSISTANCE.
- D. DEAD STOP (DS) TEMPLATING MAY BE USED ON HOLD OPEN, FRICTION AND STOP ONLY MODELS, BUT SHOULD NOT BE USED ON "SE" MODELS. THE DS POSITION IS REACHED WHEN THE SHOCK SPRING IS FULLY COMPRESSED. WHEN DS TEMPLATING IS USED, THE INITIAL DEGREE OF STOP WILL BE 5°-7° LESS THAN THE DS OPENING. FOR USE ON DOORS OPENING BACK-TO-BACK, AGAINST A WALL OR OBSTRUCTION.

410 ADJUSTMENTS:

HOLD-OPEN TENSION ADJUSTMENT (HOLD-OPEN UNIT ONLY)- USING A 5/32" BALL END ALLEN WRENCH, TURN SCREW INSIDE "LONG" END OF THE CAM CLOCKWISE TO DECREASE HOLD-OPEN TENSION AND COUNTERCLOCKWISE TO INCREASE HOLD-OPEN TENSION. TENSION SET TO MINIMUM AT FACTORY.

FRICTION TENSION ADJUSTMENT (FRICTION UNIT ONLY)- USING A 3/32" ALLEN WRENCH, TURN SCREW SHOWN CLOCKWISE TO INCREASE THE FRICTION TENSION AND TURN COUNTERCLOCKWISE TO DECREASE THE FRICTION TENSION.

DOOR THICKNESS	HINGE TYPE & STYLE	MOUNTING GROUP
1 3/8" (35)	3" WIDE BUTT	3
	3 1/2" WIDE BUTT	3
	3/4" OFFSET PIVOT	4
	CENTERHUNG PIVOT	4
1 3/4" (44)	4" WIDE BUTT	2
	4 1/2" WIDE BUTT	2
	5" WIDE BUTT	1
	3/4" OFFSET PIVOT	2
	4" SWINGCLEAR	1
	4 1/2" SWINGCLEAR	2
	5" SWINGCLEAR	2
2" (51)	SOSS 218	3
	CENTERHUNG PIVOT	4
	4 1/2" WIDE BUTT	2
	5" WIDE BUTT	1
	3/4" OFFSET PIVOT	1
	4 1/2" SWINGCLEAR	2
2 1/4" (57)	5" SWINGCLEAR	2
	SOSS 220	2
	CENTERHUNG PIVOT	4
	4 1/2" WIDE BUTT	2
	5" WIDE BUTT	2
	3/4" OFFSET PIVOT	1
2 1/4" (57)	4 1/2" SWINGCLEAR	1
	5" SWINGCLEAR	1
	SOSS 220	2
	CENTERHUNG PIVOT	4
	CENTERHUNG PIVOT	4

DIMENSIONS IN () ARE IN MILLIMETERS

SCREW DETAILS			
	QTY	WOOD	METAL
DOOR	2	#10 x 1 1/2" FILPHSMS	10-32 x 1 1/2" FILPHMS
JAMB	4	#10 x 1 1/2" FPHSMS	10-32 x 1/2" FPHMS

2. A. LOCATE "B" DIMENSION ON THE FRAME. NOTE THAT THE "B" DIMENSION IS MEASURED FROM THE CENTERLINE OF THE HINGE AS SHOWN.
- B. MORTISE FOR THE JAMB BRACKET AS SHOWN. REFER TO LEFT AND RIGHT HAND PLAN VIEWS FOR APPROPRIATE HOLE PATTERN.
- C. FOR METAL FRAMES, USE A #21 DRILL AND A 10-32 TAP IN 4 PLACES. FOR WOOD FRAMES, DRILL A 1/16" PILOT HOLE IN 4 PLACES.

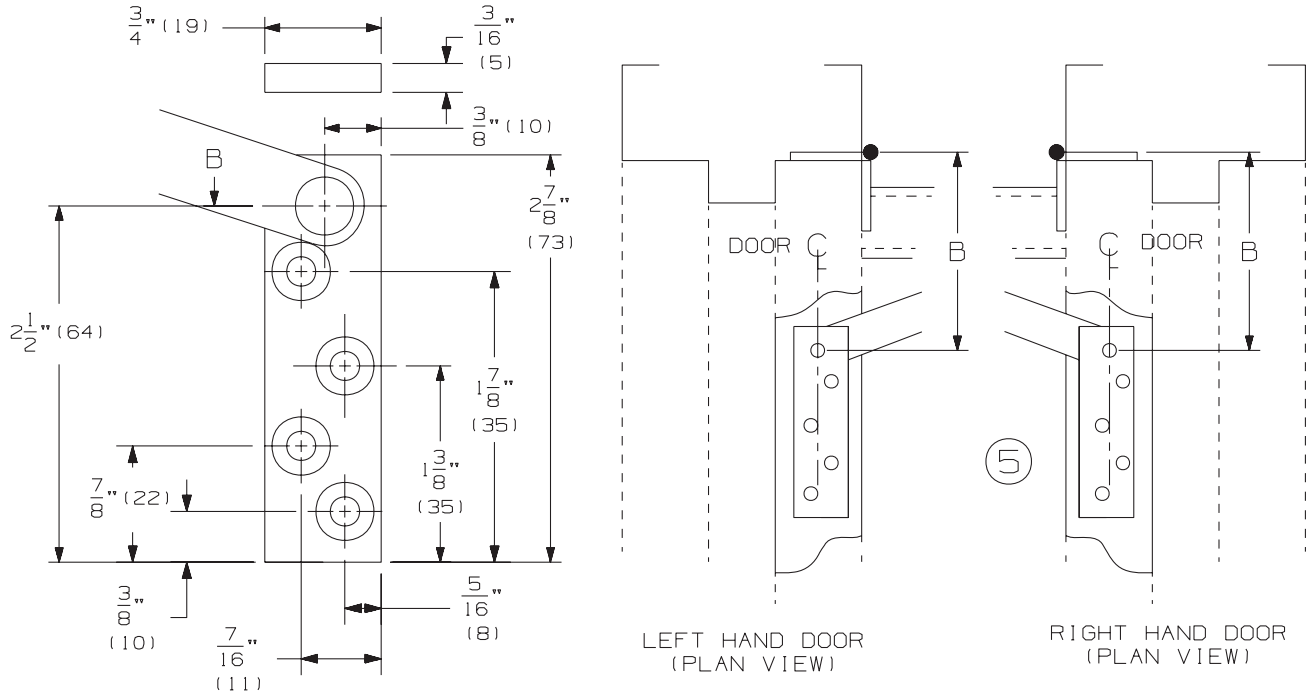

REFER TO ILLUSTRATION BELOW AND ON SHT 1 FOR THE FOLLOWING NOTES:

3. A. LOCATE "A" AND "D" DIMENSIONS ON THE CENTERLINE OF THE DOOR. NOTE THAT THE "A" DIMENSION IS MEASURED FROM THE CENTERLINE OF THE HINGE AS SHOWN.
- B. MORTISE FOR THE CHANNEL AS SHOWN IF REQUIRED.
- C. LOCATE "C" AND "E" DIMENSIONS ON THE TOP OF THE DOOR. NOTE THAT THE "C" DIMENSION IS MEASURED FROM THE CENTERLINE OF THE HINGE AS SHOWN.
- D. MORTISE FOR ARM CUTOUT AS SHOWN.
- E. FOR METAL DOORS, USE A #21 DRILL AND 10-32 TAP IN 2 PLACES. FOR WOOD DOORS, DRILL 1/8" PILOT HOLES IN 2 PLACES. MOUNTING HOLES SHOULD BE PREPARED IN THE FIELD.

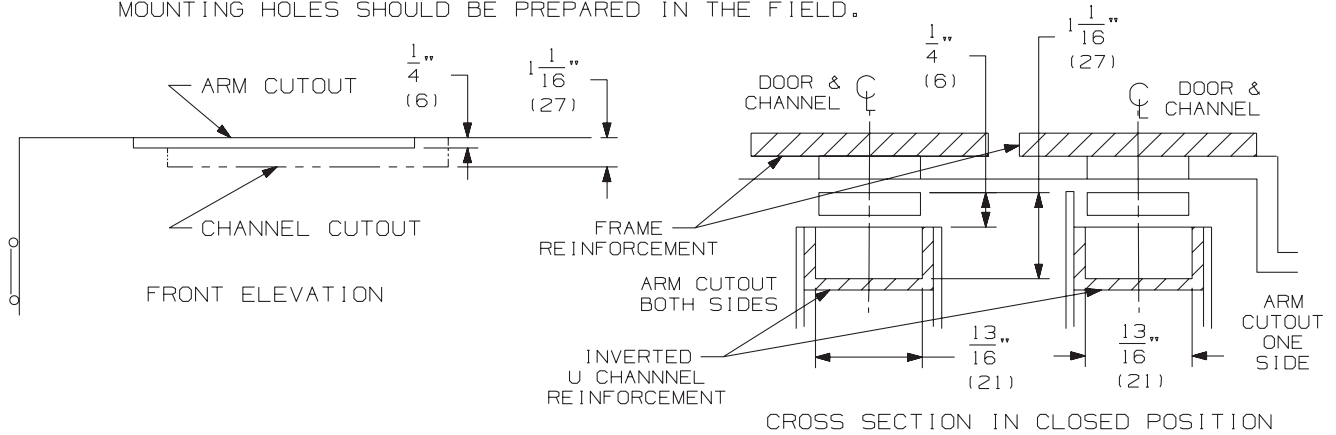

4. A. INSTALL THE CHANNEL IN THE DOOR WITH THE SHOCK SPRING TOWARDS THE HINGE EDGE OF DOOR.
- B. INSTALL JAMB BRACKET IN FRAME.

DIMENSIONS IN () ARE MILLIMETERS.

INST.410



Customer Service

1-877-671-7011

www.allegion.com



© Allegion 2014
Printed in U.S.A.
INST.410 Rev. 10/14-c