



4270101871

1990

FALCON®

Concealed Vertical Rod Panic Device

Installation Instructions

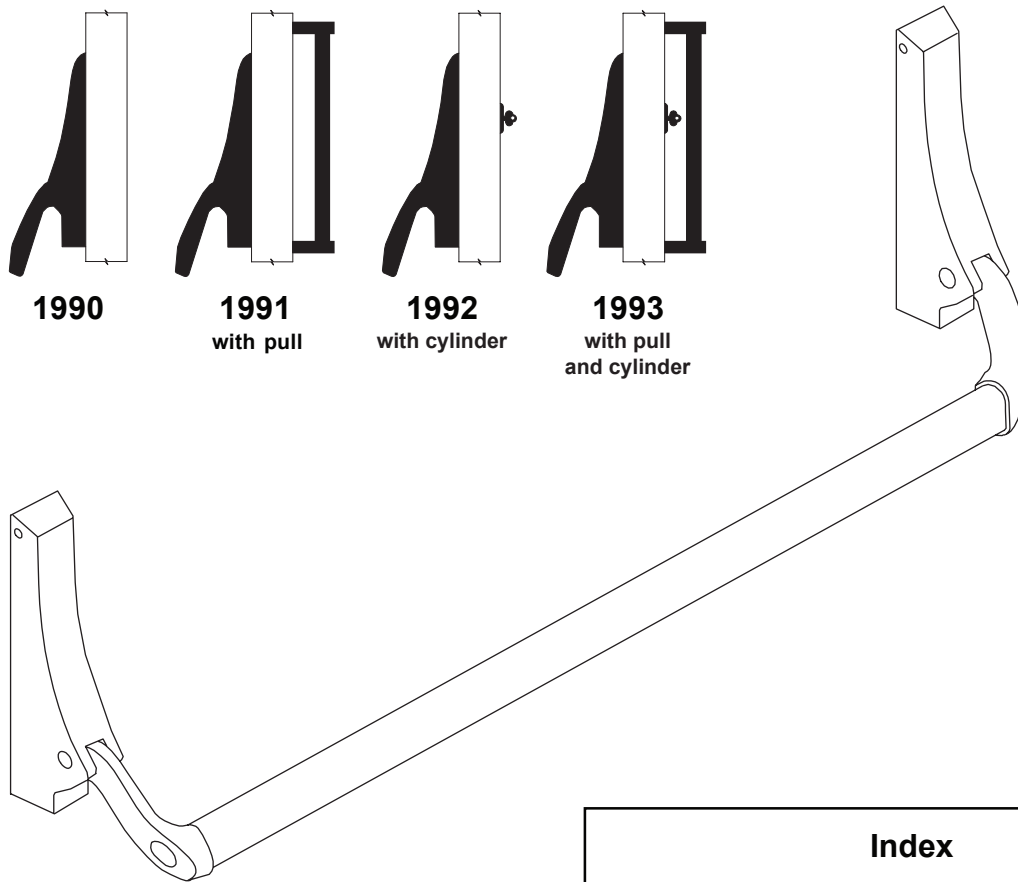
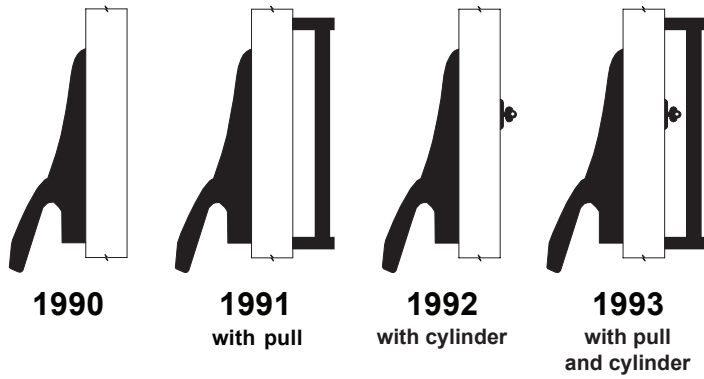

Index

- Before Installation..... 2
- Installation 2
- Series 1990 Parts List 5
- Head Jamb and Threshold Preparation .. 6
- Aluminum Door Preparation 7
- Hollow Metal Door Preparation 8

Before Installation

1. Check "Series 1990 Parts List" (see page 5).
2. Prepare door, threshold, and head jamb: aluminum door page 7; hollow metal door page 8; threshold and head jamb page 6.

⚠ NOTES ⚠

1. Handling of device can be changed.
2. Latch mounting center lines need not be the same as the housing center lines. The operating rod can work at an angle to permit mounting of latches so they will clear projections inside the door.
3. Crossbar length equals the distance between the housing vertical centerlines minus 1-3/4".

INSTALLATION

1 Install rod assemblies.

- 1a For hollow metal door, attach latch brackets to sides of top and bottom latches with #10-32 x 1/4" UFPH machine screws (Figure 1-1).
- 1b Slide top rod assembly into door. Hollow metal door: Secure each latch bracket to door with two #10-32 x 3/8" FPH machine screws. Aluminum door: Secure top latch to door with two #10-32 x 1/4" UFPH machine screws through face of door into front mounting holes on latch.
- 1c Install bottom rod assembly into door. If using rod latch (RL) bottom rod assembly: For hollow metal door, secure each latch bracket to door with two #10-32 x 3/8" FPH machine screws; for aluminum door, secure top latch to door with two #10-32 x 1/4" UFPH machine screws through face of door into front mounting holes on latch.
- 1d For hex bottom rod, install hex rod guide in door with #10-24 x 3/8" UFPHTC screws (Figure 1-2).
- 1e Install rod bearing bushing over end of each rod and secure with retaining ring (Figure 1-3).

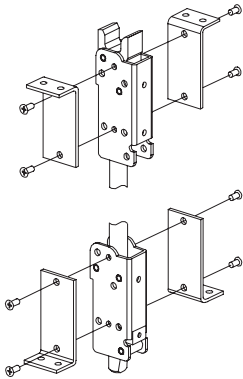

Figure 1-1

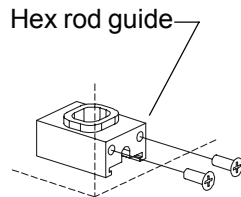

Figure 1-2

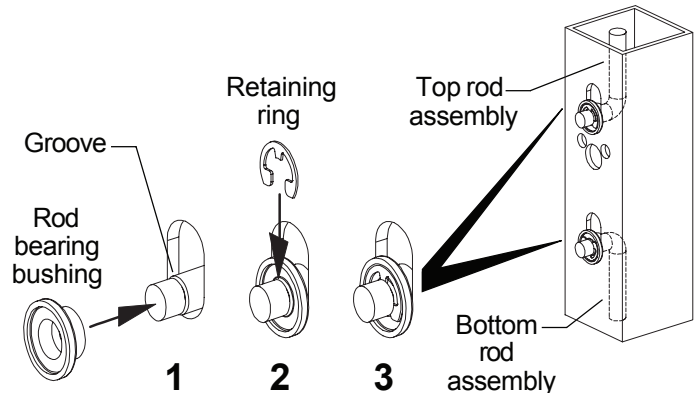

Figure 1-3

1f Check latch operation and rod length adjustment:

- a. Place traveler over rod ends.
- b. Slide traveler up. Top latch should release and hold rods in up position, and bottom latch should be completely retracted (flush with bottom edge of door).
- c. Move top latch back to locked position. Rods should drop down, locking top latch and extending bottom latch approximately 1/2".
- d. If necessary, adjust rod lengths for correct operation. Remove traveler after adjustment.

2 Install cylinder

Install cylinder. If required, cut cylinder tailpiece as shown. Heads of cylinder mounting bolts must be flush with door surface.

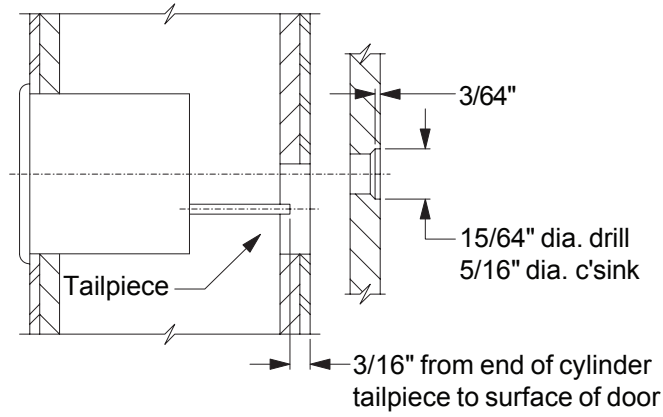

3 Install pinion cam and traveler.

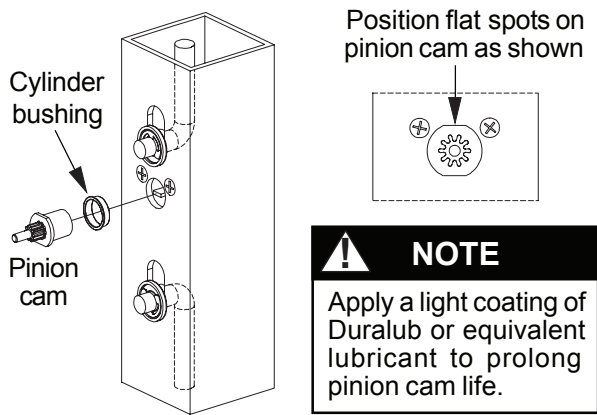

Figure 3-1

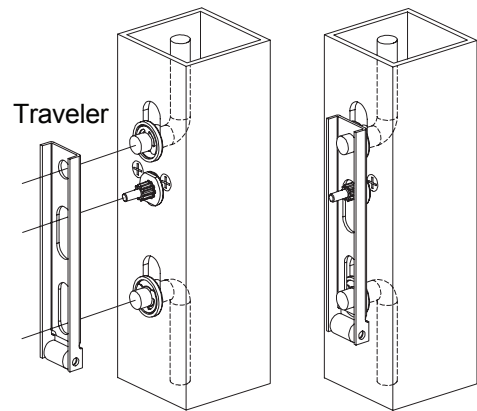

Figure 3-2

4 Install retractor.

Install retractor over pinion cam (Figure 4-1). **Position retractor as shown in Figure 4-2 for holdback (HB) or night latch (NL) function.**

Hold-back (HB): Turning key one complete rotation retracts latch bolt. If key is removed in this position, latch bolt stays retracted. Returning key to original position before removing allows latch bolt to extend.

Night latch (NL): Turning key as far as it will go retracts latch bolt. Key must be returned to original position to be removed, leaving the door locked.

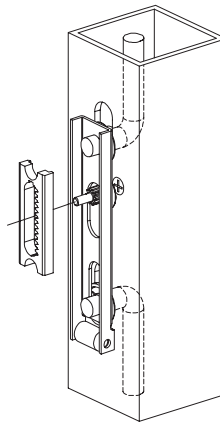
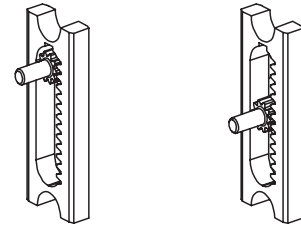

Figure 4-1

Hold-back (HB) Night latch (NL)



Install retractor with teeth to right as shown for both RHR and LHR doors; this makes all keys function in the same direction

Figure 4-2

5 Install top strike.

Install top strike with four #8-32 x 1/4" flat head Phillips undercut screws. The top strike is fabricated off center to permit pin adjustment by rotating the strike 90°. Use strike shims (supplied with strike) as needed to adjust the projection of the strike pin.

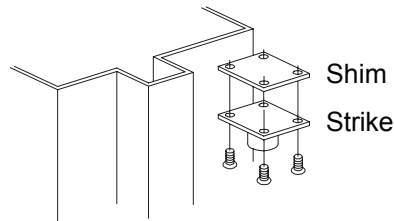

6 Install housing mounting studs, housings, and crossbar.

6a Install four housing mounting studs (Figure 6-1).

6b Install lock stile housing over mounting studs and secure with set screws (Figure 6-2). Test operation.

6c Install crossbar and hinge stile housing (Figure 6-3). Secure housing with set screws. Secure crossbar with two 1/4-20 x 1" Taptite screws.

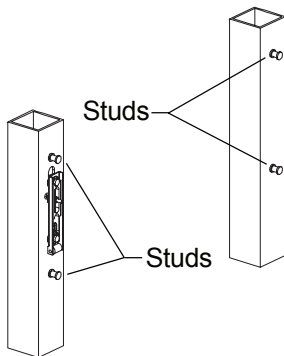

Figure 6-1

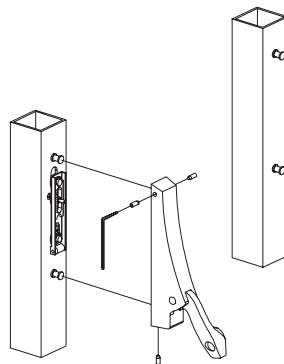

Figure 6-2

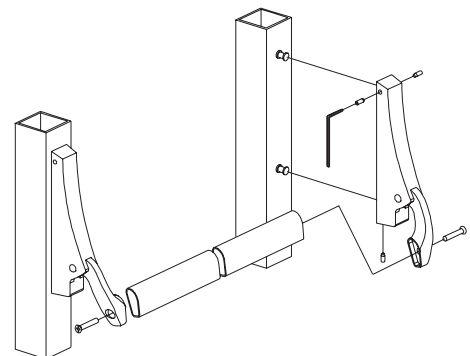
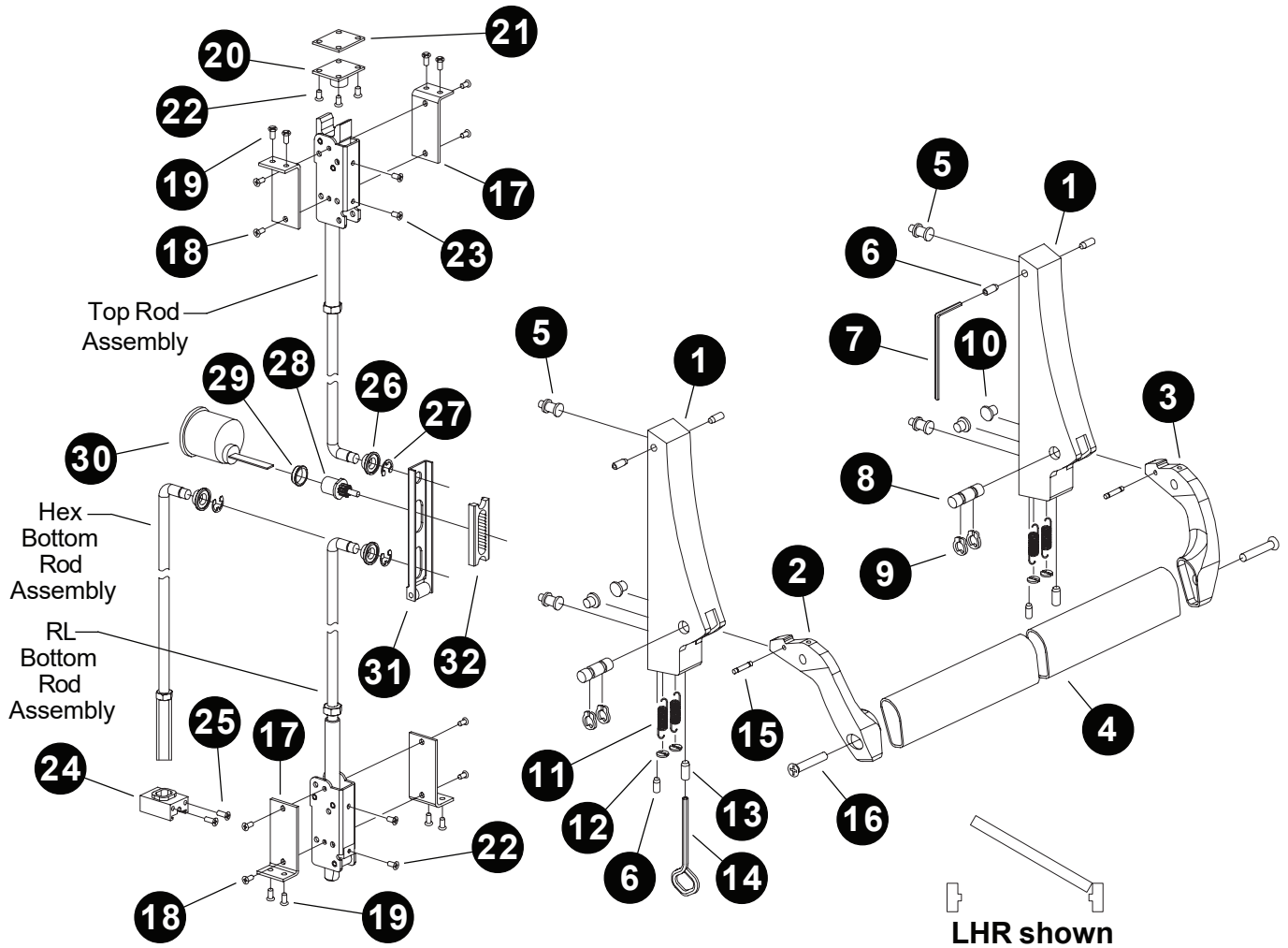

Figure 6-3

SERIES 1990 PARTS LIST



Item	Qty.	Description	Item	Qty.	Description
1	2	Housing	17	4	Latch bracket (hollow metal doors only)
2	1	Lever arm, LH	18	8	#10-32 x 1/4" UFPHMS
3	1	Lever arm, RH	19	8	#10-32 x 3/8" FPHMS
4	1	Crossbar	20	1	PB48 strike
5	4	Housing mounting stud	21	3	PB48 strike shim
6	6	1/4-20 x 3/8" hex socket head set screw	22	4	#8-32 x 1/2" UFPHTC
7	1	1/8" Allen wrench	23	4	#10-32 x 1/4" UFPHMS
8	2	Axle pin	24	1	Hex rod guide
9	4	Retaining ring	25	2	#10-24 x 3/8" UFPHTC
10	4	Axle bushing	26	2	Rod bearing bushing
11	4	Tension spring	27	4	Retaining ring
12	4	Spring retainer	28	1	Pinion cam
13	2	7/16-14 x 3/4" hex socket head dogging screw	29	1	Cylinder bushing
14	1	Dogging key	30	1	Rim cylinder (optional; sold separately)
15	2	Spring pin	31	1	Traveler
16	2	1/4-20 x 1" Taptite	32	1	Retractor

PARTS LIST (CONTINUED)

TOP ROD ASSEMBLY

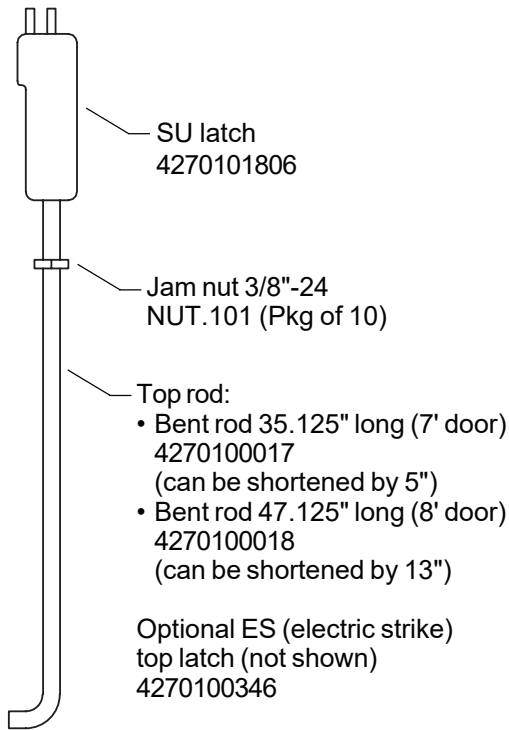

ROD LATCH (RL) BOTTOM ROD ASSEMBLY

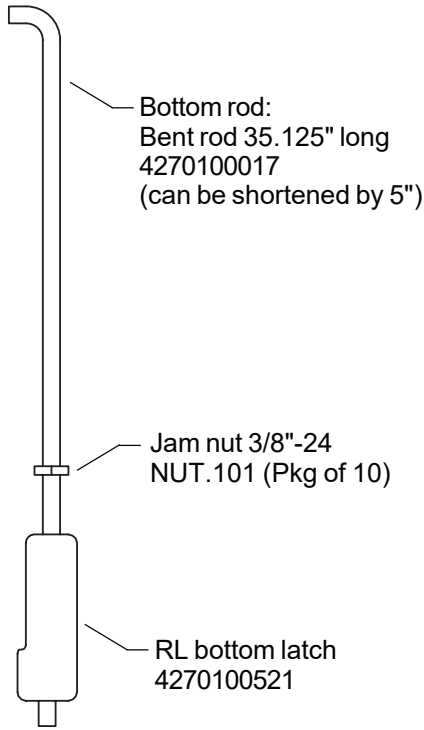

HEX BOTTOM ROD ASSEMBLY

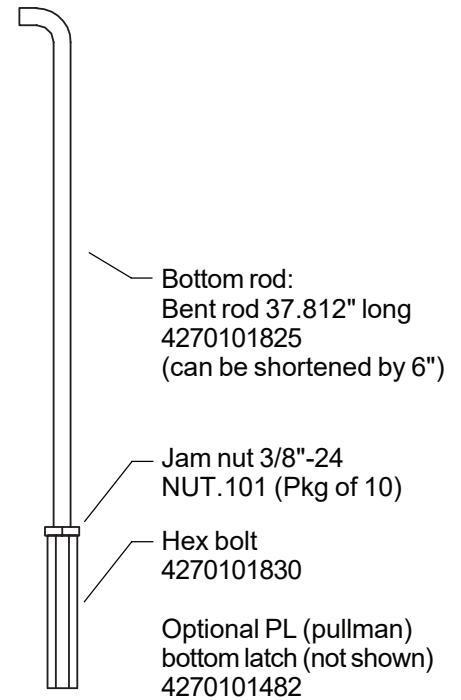

HEAD JAMB AND THRESHOLD PREPARATION

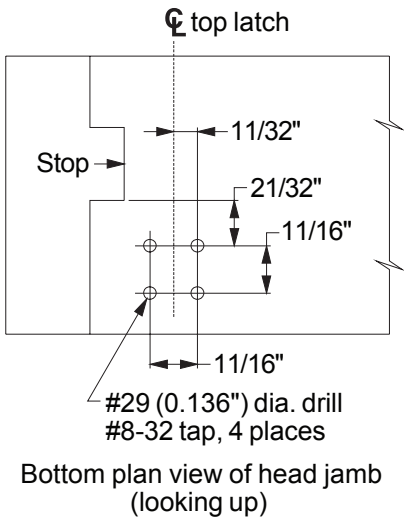

**Upper Strike
Head Jamb Preparation**

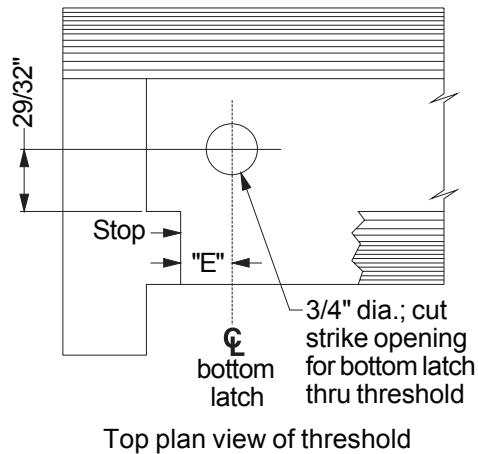

**Rod Latch (RL) or Hex Bolt
Threshold Preparation**

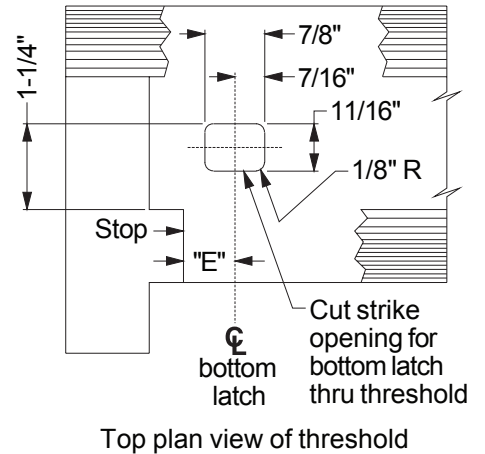

**Pullman Latch
Threshold Preparation**

ALUMINUM DOOR PREPARATION

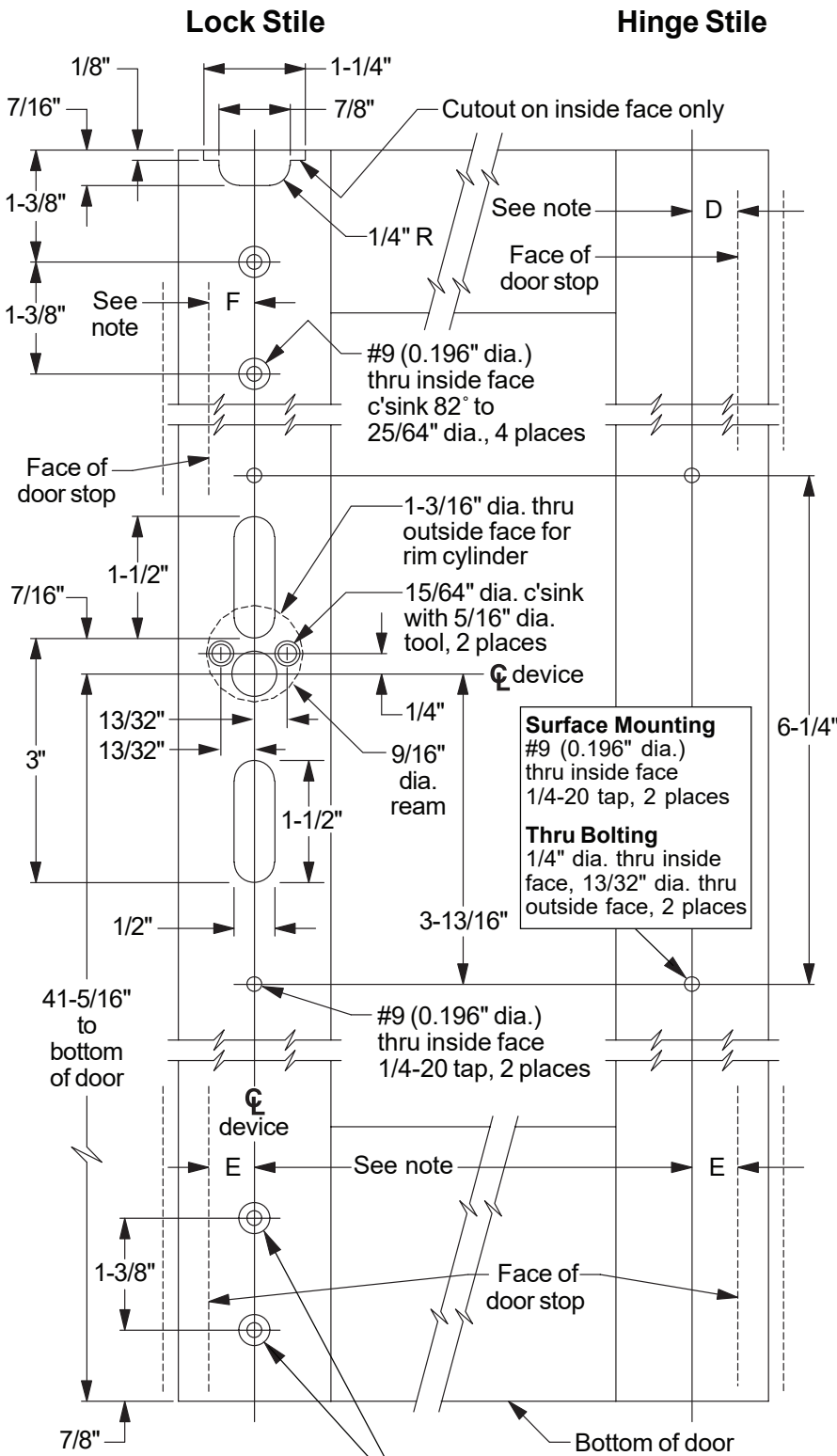

NOTES

D: Dimension from door stop face to housing ϕ is 3/4" minimum for medium and wide stiles.

E and F: Dimension from door stop face to top or bottom latch ϕ can be the same as "D" or can vary to suit door conditions.

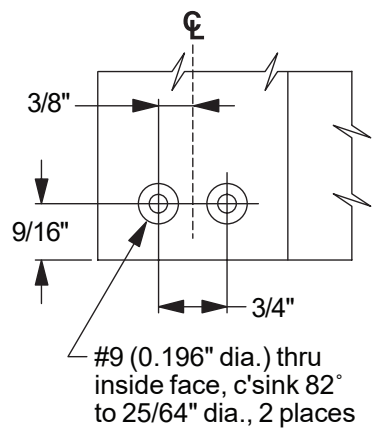

Pullman (PL) and Rod Latch (RL) Door Preparation

Hex Bottom Bolt Door Preparation

HOLLOW METAL DOOR PREPARATION

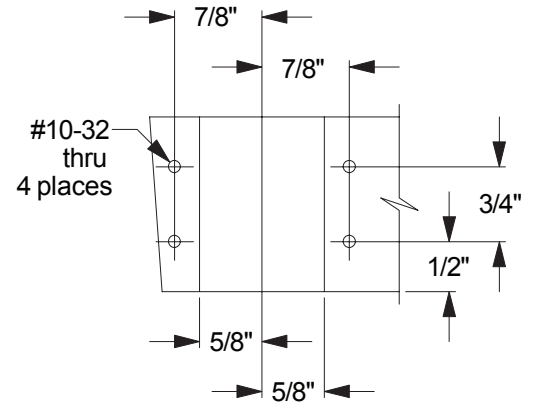
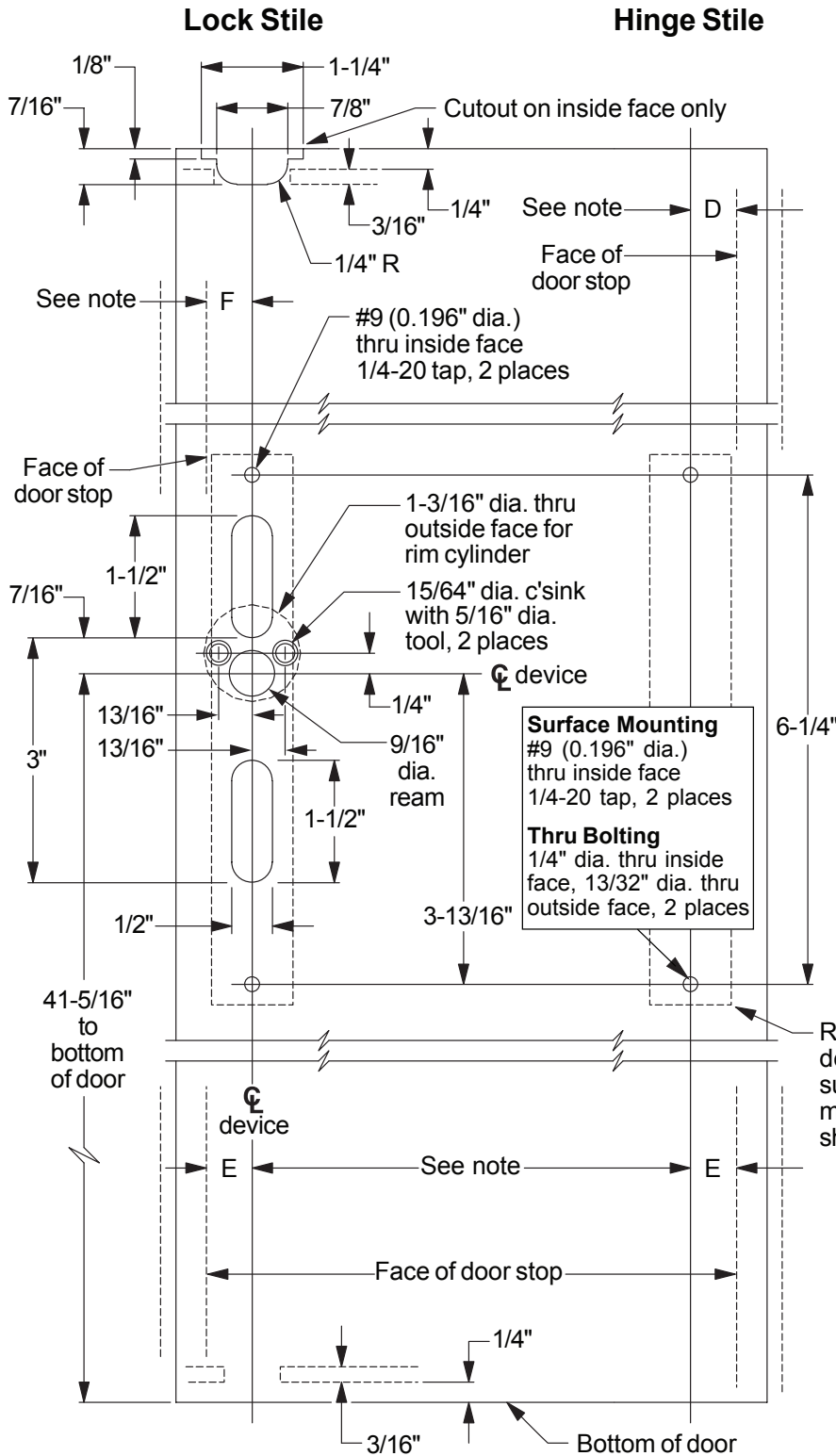

Top view of door
(bottom view of door is typical)

Top and Bottom Latch Bracket Door Preparation

NOTES

D: Dimension from door stop face to housing ϕ is 3/4" minimum for medium and wide stiles.

E and F: Dimension from door stop face to top or bottom latch ϕ can be the same as "D" or can vary to suit door conditions.

NOTE

Reinforcement in head jamb for top strike is 3/16" minimum. Reinforcement in stile for panic device is 1/8" minimum.