



70TJ SERIES MAGNETIC LOCK

INSTALLATION INSTRUCTIONS & CUT-OUT TEMPLATE

The 70TJ Series magnet is powered by 12 or 24VDC only. Schlage offers several power supplies which can be used to power magnetic locks. Magnetic locks are usually controlled by an access control reader (card, prox, etc.) and an egress device such as an exit device with a switch, pushbutton and/or motion detector. In most cases it is required that activation of building's fire alarm system cause all magnetic locks to unlock. Consult local authority having jurisdiction regarding system requirements for local life safety and electrical codes.

1) Place template on frame face as shown. Leave room if required for existing door hardware such as vertical rod panic hardware, etc. Drill required holes.

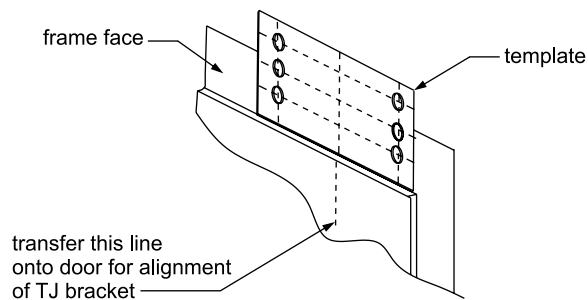

NOTE: Many frame faces are not tall enough for all holes to be drilled. In such cases, prep the three holes which fall on the frame face for blind nuts and use masonry anchors or other appropriate fasteners for the top two holes. It is critical that the three fasteners on the frame face are properly installed.

2) Refer to wiring chart and make wiring connections.

| | |
|---|--------------|
| WIRING: | |
| Red (+) | 0.300A@12VDC |
| Black (-) | 0.150A@24VDC |
| White | MBS C |
| Green | MBS NO |
| Orange | MBS NC |
| Contact shown with lock unlocked | |
| Yellow | DSM C |
| Blue | DSM NO |
| Brown | DSM NC |
| Contact shown with door opened | |

3) Install magnet.

NOTE: Top two blind nuts might fall on wall area. Use appropriate reinforcement as required to attain rated holding force.

NOTE: Magnet and armature must mate when door is in closed (and latched if applicable) position. Adjust by adding/subtracting shim washers.

A. Drill a 9/32" hole.

B. Refer to Figure 1.
• Assemble the supplied parts.
• Insert into hole.

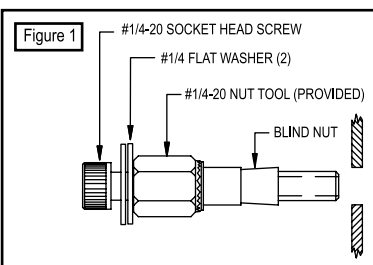

C. While holding tool in place with wrench, tighten to collapse nut with hex wrench. **IMPORTANT: DO NOT OVERTIGHTEN.**

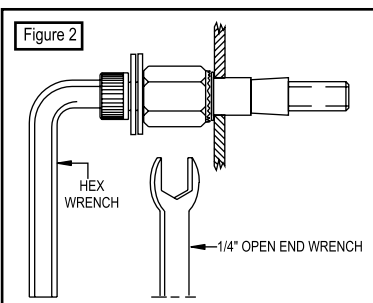

D. Figure 3 shows completed installation of blind nut.

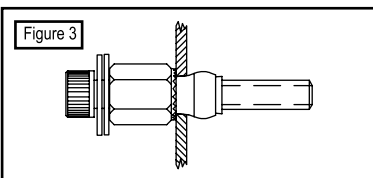

E. Repeat steps A, B and C for additional blind nuts.

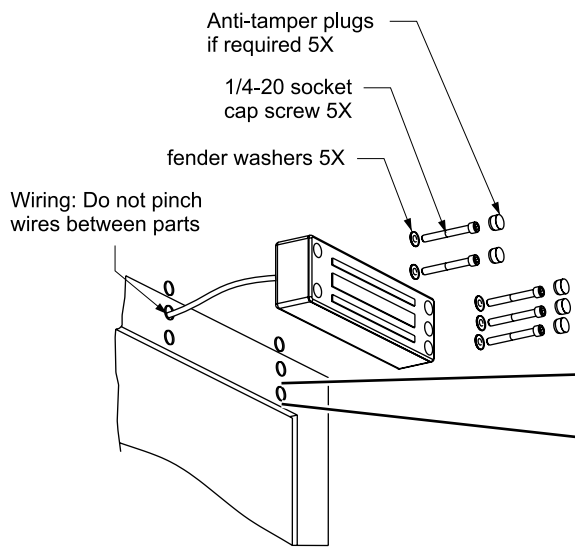

4) Prepare TJ bracket
Drill holes for armature
Mark holes for mounting armature

NARROW STILE ALUMINUM DOOR

TYPICAL HOLLOW METAL DOOR w/WEB

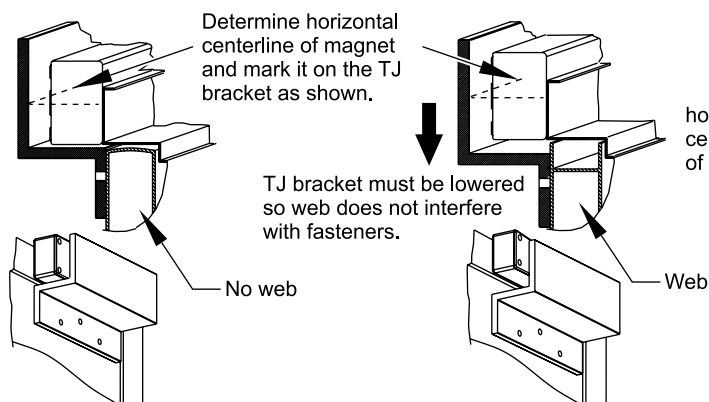

Line up template with horizontal centerline and center it on the TJ bracket (measure and mark the center) Tape the template to the TJ bracket and drill holes as required by template.

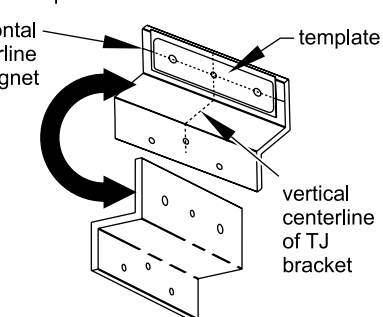

5) Install armature onto TJ bracket using fasteners in order and orientation as shown. Drill holes for TJ bracket as specified. Mount TJ bracket assembly onto door.

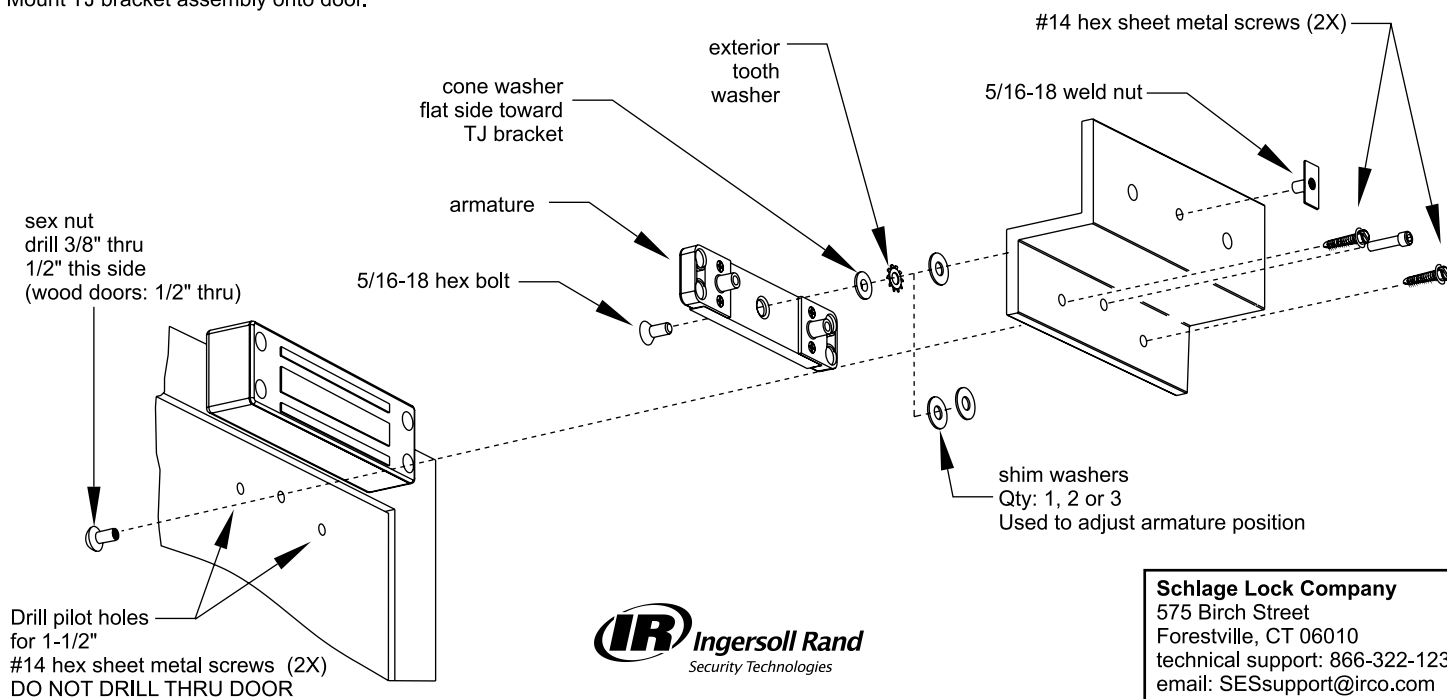

Schlage Lock Company
575 Birch Street
Forestville, CT 06010
technical support: 866-322-1237
email: SESsupport@irco.com
web: www.irsupport.net

