



INST.79

Surface Overhead Holder

Installation Instructions

OVERHEAD HOLDERS OR STOPS MUST BE INSTALLED BEFORE CLOSERS

1. A. DETERMINE THE MOUNTING BEING USED FROM ILLUSTRATION BELOW.
- B. SELECT MOUNTING GROUP NUMBER FROM CHART BELOW. MOST CONTINUOUS HINGES ARE GROUPED WITH 4 1/2" WIDE BUTT OR 4 1/2" SWING CLEAR HINGE.
- C. USING THE MOUNTING GROUP NUMBER AND THE OVERHEAD HOLDER OR STOP SIZE AND THE DEGREE OF OPENING DESIRED, FIND "A" AND "B" DIMENSIONS FROM CHART ON PAGE 3. FOR DEAD STOP ADD 7/8" (22) TO THE "A" AND "B" DIMENSIONS FROM THE CHART. SEE NOTE D FOR INFORMATION ABOUT DEAD STOP.

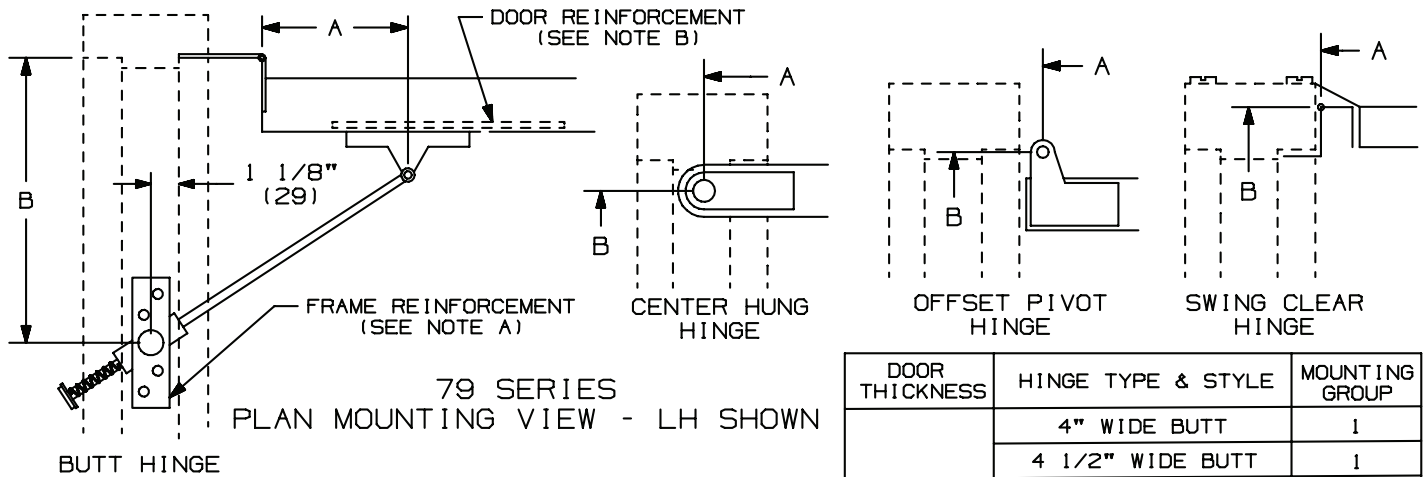

DOOR THICKNESS	HINGE TYPE & STYLE	MOUNTING GROUP
1 3/4" (44mm)	4" WIDE BUTT	1
	4 1/2" WIDE BUTT	1
	5" WIDE BUTT	1
	3/4" OFFSET PIVOT	1
	4 1/2" SWINGCLEAR	1
	5" SWINGCLEAR	1
2" (51mm)	CENTERHUNG PIVOT	2
	4 1/2" WIDE BUTT	1
	5" WIDE BUTT	1
	3/4" OFFSET PIVOT	1
	4 1/2" SWINGCLEAR	1
	5" SWINGCLEAR	1
2 1/4" (57mm)	SOSS 220	1
	CENTERHUNG PIVOT	2
	4 1/2" WIDE BUTT	1
	5" WIDE BUTT	1
2 1/4" (57mm)	SOSS 220	1
	CENTERHUNG PIVOT	2
	4 1/2" WIDE BUTT	1

NOTES:

- A. HOLLOW METAL FRAMES SHOULD BE PROPERLY REINFORCED WITH A 3/16" (5) MINIMUM THICKNESS BY 12" (305) MINIMUM LENGTH PLATE.
- B. HOLLOW METAL DOORS SHOULD BE PROPERLY REINFORCED WITH A 3/16" (5) MINIMUM THICKNESS BY 2 1/2" (64) MINIMUM WIDTH PLATE.
- C. STOP ONLY UNITS ARE PERMITTED ON MANY FIRE DOOR APPLICATIONS. HOWEVER, MECHANICAL HOLD-OPEN DEVICES THAT REQUIRE MANUAL RELEASE ARE NOT PERMITTED FOR USE ON ANY FIRE DOOR AS OUTLINED ON NFPA80 ® OR NFPA101 ®.
- D. DEAD STOP (DS) TEMPLATING MAY BE USED ON HOLD OPEN AND STOP ONLY MODELS. THE DS POSITION IS REACHED WHEN THE SHOCK SPRING IS FULLY COMPRESSED. WHEN DS TEMPLATING IS USED, THE INITIAL DEGREE OF STOP WILL BE 5° -7° LESS THAN THE DS OPENING. FOR USE ON DOORS OPENING BACK-TO-BACK, AGAINST A WALL OR OBSTRUCTION.

HOLD-OPEN TENSION ADJUSTMENT USING A 3/4" WRENCH, TURN NUT AT THE END OF BAR. TO INCREASE THE HOLD-OPEN TENSION, TURN NUT CLOCKWISE. TO DECREASE THE HOLD-OPEN TENSION, TURN NUT COUNTER-CLOCKWISE.

NOTE: DIMENSIONS IN () ARE MILLIMETERS.

SCREW DETAILS			
	QTY	WOOD	METAL
JAMB	4	#18 x 2" FPHSMS	5/16"-18 x 1 1/2" FPHMS
DOOR STD	2	5/16"-18 x 2 1/2" PPHMS	5/16"-18 x 2 1/2" PPHMS
	2	5/16"-18 HEX CAP NUTS	5/16"-18 HEX CAP NUTS
	1	FLAT WASHER	FLAT WASHER
	3	SPLIT LOCK WASHER	SPLIT LOCK WASHER
DOOR SEX BOLT	2	∅ 1/2" x 1 9/16" SEX BOLTS	∅ 1/2" x 1 9/16" SEX BOLTS
	2	5/16"-18 x 1 1/2" FPHMS	5/16"-18 x 1 1/2" FPHMS

2. A. LOCATE "B" DIMENSION ON THE STOP. NOTE THAT THE "B" DIMENSION IS MEASURED FROM THE CENTERLINE OF THE HINGE AS SHOWN.
- B. FOR METAL FRAMES, USE A F DRILL AND A 5/16"-18 TAP IN 4 PLACES. FOR WOOD FRAMES, DRILL A 1/4" PILOT HOLE IN 4 PLACES.

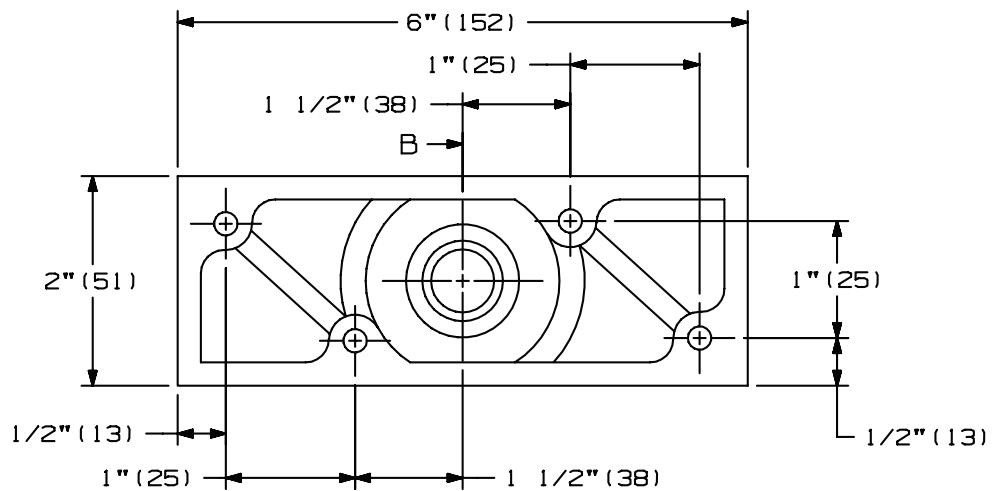

JAMB BRACKET

3. A. LOCATE "A" DIMENSION ON THE DOOR. NOTE THAT THE "A" DIMENSION IS MEASURED FROM THE CENTERLINE OF THE HINGE AS SHOWN.
- B. CHOOSE THE TYPE OF FASTENERS BEING USED TO MOUNT THE DOOR BRACKET TO THE DOOR. MOUNTING HOLES SHOULD BE PREPARED IN THE FIELD.
 1. USING SCREWS, FLAT WASHERS, SPLIT WASHERS, AND HEX CAP NUTS WHICH ARE PROVIDED, DRILL 1 3/4" (44) DOWN FROM STOP 11/32" (13) DIAMETER THROUGH DOOR IN 4 PLACES.
 2. OPTIONAL, USING SEX BOLTS, DRILL 1 3/4" (44) DOWN FROM STOP 1/2" (13) DIAMETER THROUGH DOOR IN 4 PLACES. NOT PROVIDED STANDARD, BUT AVAILABLE ON REQUEST.

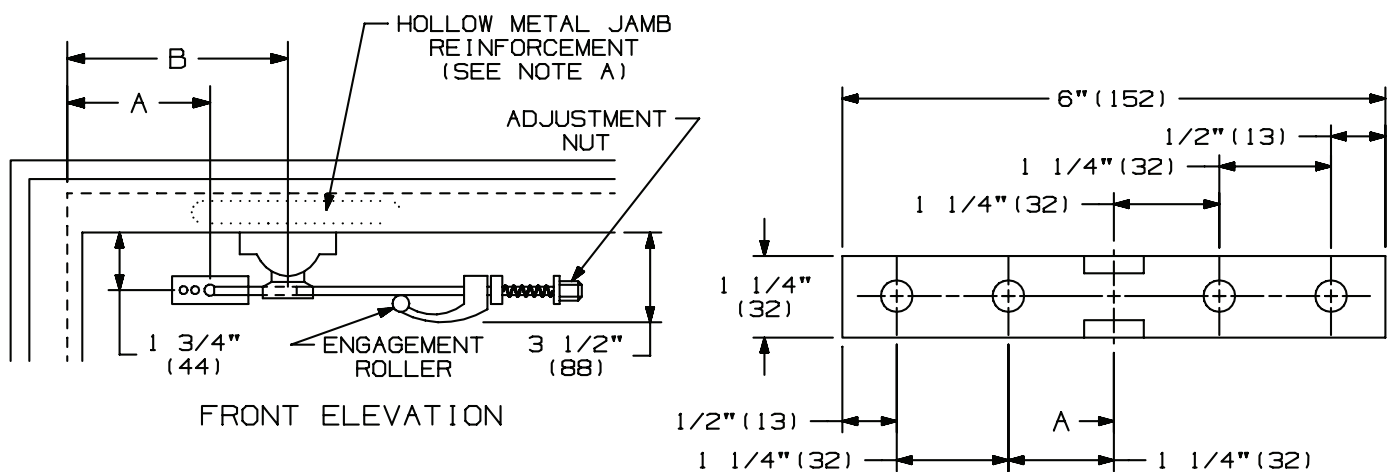

DOOR BRACKET

4. A. INSTALL JAMB BRACKET ON THE STOP.
- B. INSTALL THE DOOR BRACKET ON THE DOOR.

NOTE: DIMENSIONS IN () ARE MILLIMETERS.

MOUNTING GROUPS 1 & 2
 79 SERIES SURFACE OVERHEAD STOP & HOLDER
 CAUTION: "A" & "B" DIMENSIONS ARE MEASURED FROM THE
 CENTERLINE OF PIVOT, NOT EDGE OF DOOR
 FOR DEAD STOP ADD 7/8" (22) TO THE "A" AND "B" DIMENSIONS
 HO=HOLD-OPEN FOR HOLDERS, OPENING FOR STOPS

DEGREE	85 HO		90 HO		95 HO		100 HO		105 HO		110 HO		BAR LENGTH
	A	B	A	B	A	B	A	B	A	B	A	B	
792	IN. 23 1/16-27	4 1/4	9 5/16	4	8 7/8	3 3/4	8 1/2	3 1/2	8 1/8	-	-	-	17 15/16
	mm	108	237	102	225	95	216	89	206	-	-	-	456
793	IN. 27 1/16-33	6 1/16	11 1/16	5 13/16	10 7/16	5 7/16	10 1/16	5 1/8	9 11/16	4 13/16	9 3/8	4 9/16	20 5/8
	mm	154	281	148	265	138	256	130	246	122	238	116	524
794	IN. 33 1/16-39	8 5/8	13 5/8	8	13 3/16	7 9/16	12 3/4	7 1/16	12 7/16	6 1/2	12 5/16	6 1/16	23 5/16
	mm	219	346	203	335	192	324	179	316	165	313	154	592
795	IN. 39 1/16-45	11 1/4	16 1/8	10 11/16	15 7/16	10 1/8	14 7/8	9 1/2	14 9/16	9 1/16	14 1/8	8 11/16	26 13/16
	mm	286	410	271	392	257	378	241	370	230	359	221	681
796	IN. 45 1/16-54	-	-	13	18 1/8	12 7/16	17 3/8	11 7/8	16 3/4	11 1/2	16 1/16	10 7/8	30 5/16
	mm	-	-	330	460	316	441	302	425	292	408	276	770
792	IN. 27 1/16-33	4 9/16	9 1/16	4 1/4	8 13/16	4	8 9/16	3 11/16	8 3/8	3 9/16	8 1/8	-	17 15/16
	mm	116	230	108	224	102	217	94	213	90	206	-	456
793	IN. 33 1/16-39	6 1/8	11	5 3/4	10 5/8	5 1/4	10 1/2	5 1/16	10 1/8	4 13/16	9 7/8	4 11/16	20 5/8
	mm	156	279	146	270	133	267	129	257	122	251	119	524
794	IN. 39 1/16-45	8 3/8	13 13/16	8	13 1/4	7 7/16	12 15/16	7	12 5/8	6 15/16	12 1/16	6 5/8	23 5/16
	mm	213	351	203	337	189	329	178	321	176	306	168	592
795	IN. 45 1/16-51	11	16 3/8	10 7/16	15 3/4	9 3/4	15 3/8	9 1/2	14 3/4	9 1/16	14 3/8	8 13/16	26 13/16
	mm	279	416	265	400	248	391	241	375	230	365	224	681
796	IN. 51 1/16-57	13 9/16	19	12 13/16	18 5/16	12 1/4	17 5/8	11 13/16	17	11 5/16	16 1/2	10 7/8	30 5/16
	mm	344	483	325	465	311	448	300	432	287	419	276	770

NOTE: DIMENSIONS IN () ARE MILLIMETERS.

INST.79



Customer Service
1-877-671-7011 www.allegion.com/us



© Allegion 2014
Printed in U.S.A.
INST.79 Rev. 01/14-b